

SET-UP / INSTALLATION INSTRUCTIONS

for SLACK CABLE SINGLE AND BI-DIRECTIONAL SWITCHES with LATCH PLATE(S)

04953-132 (RH - MBB)

04953-142 (LH - MBB)

04954-214 (MBB)

Note: Seal unused conduit opening(s) with approved plug(s).

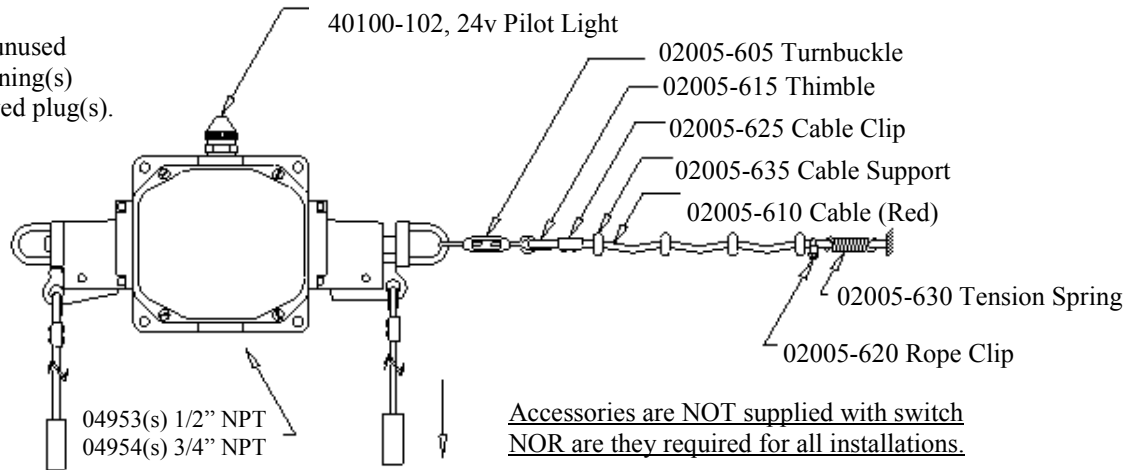

Accessories are NOT supplied with switch
NOR are they required for all installations.

Since every installation is unique and separate, the following instructions can be considered flexible. There are some basic switch setup procedures that must be observed and they are indicated by the symbol (>). The balance of the suggestions and information is subject to change to accommodate those most familiar and responsible for the installation.

INSTALLATION:

1. Observe all SAFETY REQUIREMENTS and PROCEDURES during installation, set-up and running.
2. N.E.C. and local wiring codes MUST be followed at all times.
3. The cable switch MUST be mounted on a flat surface! (Recommend 1/4-20 Bolts torque to ~60 in./lb. ~69 cm-kg)
4. The first cable support SHOULD be located 6 to 12 in. (15 to 30 cm) from the switch. (see drawing on other side)
5. The first cable support SHOULD be located so that the cable is aligned with the switch shaft within 5 degrees.
6. It is recommended that the balance of the cable supports be spaced at intervals NOT exceeding 10 feet (~3m). Supports at properly spaced intervals are necessary to ensure that the cable weight will NOT affect switch operation.
7. The maximum recommended cable length is 200 feet (60.69m) in each direction and SHOULD be in as straight a line as possible.
8. Wiring SHOULD be through the motor control circuit. (See reference diagram below)

SET-UP and USE:

- > 1. Secure (2 cable clamps per end are recommended) and adjust the SLACK cable length in either or both directions so that there is sufficient “droop” or “swale” in the cable between cable supports.
- > 2. Pull the latch plate(s) to reset switch if latched.
- > 3. Pull the trip cable on either side of the switch to test and assure that the switch is functioning properly. Reset and test other side.
- > 4. After applying control circuit power then repeat step #(s) 2 & 3.
- > 5. NOTE: All cable material will stretch with use and/or temperature variations. If the switch is set-up during extreme conditions a re-adjustment will be necessary to ensure proper switch function.

MAINTENANCE:

1. Regular Preventive Maintenance inspections are recommended.
2. Some conditions to watch for are:
 - a. Proper trip/reset tensions and slack within the trip cable.
 - b. Physical damage to the device.
 - c. Physical damage to the cable.
 - d. Frayed wiring.
 - e. Loose cable connections.
 - f. Any loose components.
 - g. Any worn components.
3. If other assistance is desired please contact the factory.

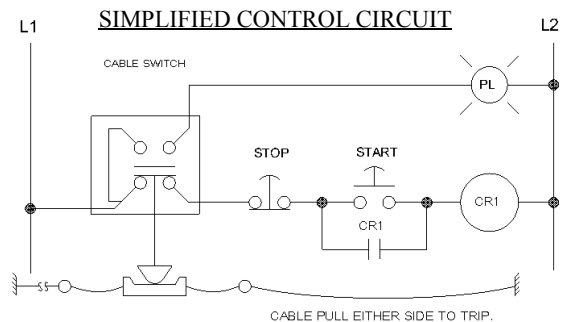

All wiring/components provided by user.

REES, Inc. Fremont, IN 46737 260-495-9811 FAX 260-495-2186 www.reesinc.com

SPECIFICATIONS / APPROVALS
for CABLE SWITCHES with LATCH PLATE(S)

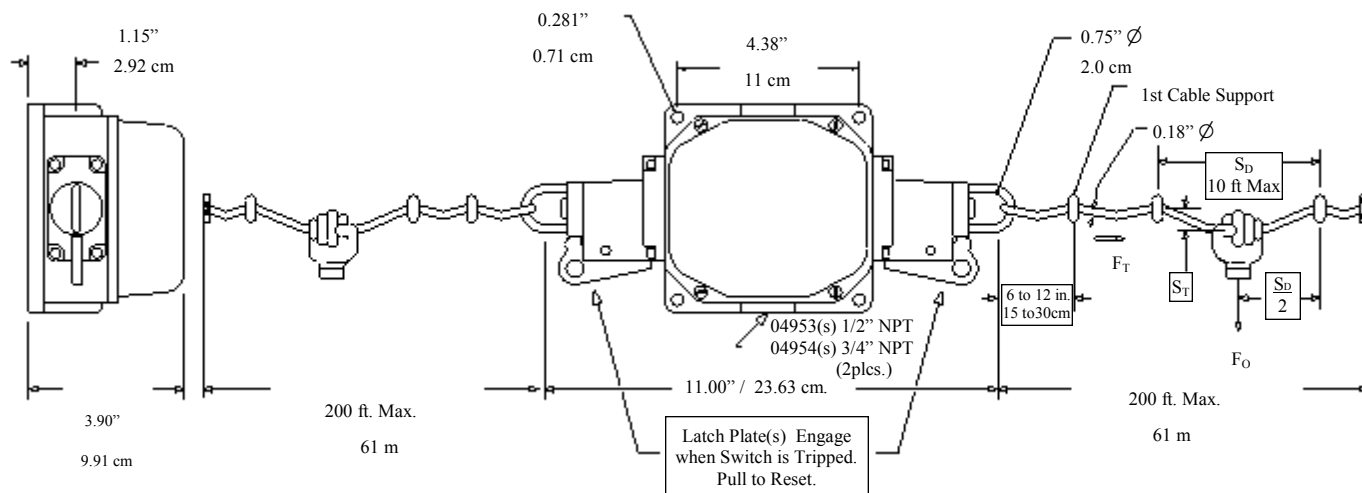

Cable(s) should be slack when installed properly and not pulled.

F_T = The value of force, along the cable, which trips the switch.

F_O = The value of force, applied by the operator perpendicular to the cable, which trips the switch.

S_D = The distance between the cable supports.

S_T = The distance the cable is deflected at the time of tripping. ** S_T is in addition to any slack "droop" req'd for set-up.

Catalog Number	Contact Arrangement	Operating End (Style)	H Conduit Opening	F_T Trip Force	$S_D = 5 \text{ ft.} / 1.5 \text{ m}$		$S_D = 10 \text{ ft.} / 3.0 \text{ m}$	
					F_O	S_T	F_O	S_T
04953-132	2 (NO / NC) *	Right	1/2" NPT	25 lb. 11.3 kg	10 lb. 4.5 kg	5 in. ** 12.7 cm	6 lb. 2.7 kg	7 in. ** 17.8 cm
04953-142	2 (NO / NC) *	Left						
04954-214	2 (2 NO + 2 NC) *	Both	3/4 " NPT	25 lb. 11.3 kg (each end)	10 lb. 4.5 kg (each end)	5 in. ** 12.7 cm (each end)	6 lb. 2.7 kg (each end)	7 in. ** 17.8 cm (each end)

* Contact are "Make Before Break" (MBB).

WARNING - DANGER

These products should only be used where point-of-operation guarding devices have been properly installed & maintained so that appropriate OSHA and ANSI B11.1 regulations & standards are met. Misapplication of the products on machinery lacking effective point-of operation safeguards can cause serious injury to the operator of that machinery.

AVERTISSEMENT - DANGER

Ces produit doivent seulement être utilisés sur des postes à risque correctement sécurisés et entretenus afin d'être conforme aux standards et réglementations en vigueur (CSA, CLC). Un mauvais usage de ces produits sur des machines et des postes de travail non sécurisés de manière efficace peut causer des blessures graves au technicien maniant ces machines.

UL listed (File E58589); CSA certified (File LR 3648); CE marked;
 These switches comply with: UL-508; CSA - C 22.2 No. 14; EN 60947-5-1: 2004 + A1:2009;
 IEC Ratings: Utilization = AC 15, DC 13; $U_e = 600 \text{ vAC}$; $U_e = 125 \text{ vDC}$; $U_i = 600 \text{ vAC}$; $U_{imp} = 2.5 \text{ kV}$; $I_{th} = 10A$
 UL/NEMA Ratings: AC = A 600; DC = N 150 Temperature: Operating = 0°C to $+55^\circ\text{C}$ (-32°F to $+131^\circ\text{F}$);
 Operating Position: Can be mounted in any position. Storage = -40°C to $+85^\circ\text{C}$ (-40°F to $+185^\circ\text{F}$)
 Mechanical Life Rating = 150,000 operations Fusing Requirements: 10A Slow Acting; 16A fast Acting

AVAILABLE ACCESSORIES:

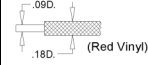
02005-605	02005-610	02005-615	02005-620	02005-625	02005-630	02005-635	40100-102
Turnbuckle Tension Adj.	Cable, Steel 	Thimble, Strain Relief	Rope Clip Standard	Cable Clip Optional	Spring, Tension	Eye Bolt Cbl. Support	24 volt Pilot Light